

June 3, 2024

To: Blue Crab Key Condo Association HOA Board

From: BCK Recreation Committee

Re: Tennis/Pickleball Court Renovation/Upgrade

The newly-formed BCK Recreation Committee provides the following background and suggestions for tennis and pickleball improvements.

Whereas the interest in pickleball has been increasing at BCK over the past few years, it has become apparent that although the existing tennis courts were recently painted to accommodate tennis and pickleball, the tennis nets are not the correct height or width for pickleball. Apparently the tennis nets have been lowed for pickleball which has resulted in damage to the reel mechanisms on both courts and adjustments are no longer possible, which impacts both sports.

The Recreation Committee would like to suggest having both courts restriped for pickleball on each side of the tennis nets and incorporate the use of portable pickleball nets. Benefits would include:

1. Elimination the need to adjust the tennis nets
2. Correct pickleball net system for improved playing environment
3. Increasing capacity from two to four pickleball courts to allow for more residents to play while also minimizing wait time to play.

This re-striping plan would maintain the two existing tennis courts and the mobile pickleball nets on wheels will allow for them to be easily moved to the side for those wishing to play tennis.

A bid on the re-striping of the 2 tennis courts was received at a cost of **\$2,930** from a licensed and insured contractor (Southwest Tennis Courts). A copy of their proposal and a diagram of the proposed new line layout is attached hereto. Note that the cost includes the removal and replacement of the two existing cranking devices for both tennis nets.

The contractor suggested the *Picklenet Deluxe* net system which is an upgraded net and frame approved for outdoor use. This can be ordered from amazon at a cost of \$489.85 per net (including sales tax) for a total equipment cost of **\$1,959.40**.

The total cost for there suggested improvements will be **\$4,889.40**.

Since Pckleball is the #1 fastest growing sport in the U.S., this would allow Blue Crab Key Condos to provide increased enjoyment and value for existing and future owners.

Thank you in advance for your thoughtful consideration.

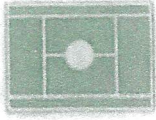

# SOUTHWEST TENNIS COURTS

239 747 1781 OFFICE  
509 738 0074 CELL  
SOUTHWEST TENNIS COURTS

2828 BEACH PARKWAY W  
CAPE CORAL FLORIDA  
33914

Gary Williams  
Blue Crab Key Tennis Court  
913-558-7581  
Zeepo5@outlook.com

SCOPE OF WORK: Tape and block out existing Pickleball lines on two Tennis Courts. Paint blue inbounds color. (match color the best that we can). Apply two sets of Pickleball lines(centered) on each side of Tennis nets. Remove and replace two external cranks.

Please note: If you accept this proposal, please return it ASAP. We schedule the work in order of signed proposals.

All material is guaranteed to be as specified. All work to be completed in a workman like matter. According to standard practices. Any alterations or deviations from the above specifications involving extra costs will be executed only upon written orders and will become an extra charge over and above the estimate. All agreements contingent upon strikes, accidents or delays beyond our control. Owner to carry fire, tornado and other necessary insurance. The contractor agrees to carry workmen's compensation and public liability insurance required by the United States Government and the State in which this work is to be performed.

We propose hereby to furnish materials and labor complete in accordance with the above specifications for the sum of \$2,930.00

Authorized signature: Shawn Martin Date 4, 01, 2024

If the forgoing meets with your acceptance, kindly sign and return a copy of the proposal. Upon its receipt it is understood the forgoing, including the terms and conditions set forth above, will constitute the full and complete agreement between us.

Acceptance of proposal: \_\_\_\_\_ Date \_\_\_\_/\_\_\_\_/\_\_\_\_  
This contract is valid for up to 60 days.

Add Shuttle Board  
on a tennis court  
[fix]

One of the issues is that the current tennis nets are not the correct height or width for pickleball. Players try to adjust the nets to the correct pickleball net height resulting in breakage of the reel mechanism. The mechanisms are currently broken on both courts, and adjustments are no longer possible, which impacts both sports.

A few suggested improvement considerations:

1. Elimination of tennis net adjustment
2. Correct pickleball net system
3. Total of four pickleball courts, minimizing wait times to play

The following restriping plan would not eliminate the two tennis courts as the planned pickleball nets are on wheels and could be moved during tennis play.

Possible committee responsibilities: being proactive in communicating court maintenance and potential safety issues to the board and the disassembly and storage of the portable nets in the clubhouse when necessary (ex: hurricane).

A bid on the restriping of the 2 courts was received at a cost of ~~\$2700.00~~ <sup>2930.00</sup> from a licensed and insured contractor (Southwest Tennis Courts). Attached is a diagram of the proposed line layout. This layout can be seen at Joe Stonis park in Cape Coral located off the island and north of Pine Island Rd.

The contractor suggested the Picklenet Deluxe net system which is an upgraded net and frame approved for outdoor use. This can be ordered from Amazon.com at a cost per net of \$489.85 tax included.

## Two Pickleball Courts per Tennis Court

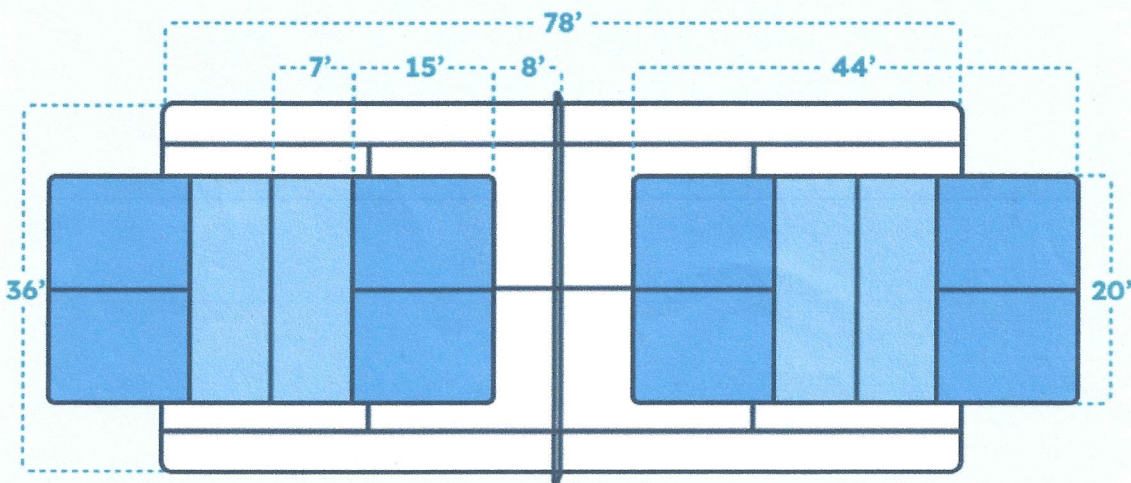

Tennis Net